



**California State Polytechnic University, Pomona
Degree Curriculum Sheet**

Plan (Major) ELECTRICAL ENGINEERING
Subplan/Option _____

Catalog Year 2012-2013
Minimum Units Required 198

Name _____
Student ID _____

TGA _____
GWT Satisfied _____ Yes _____ No

Required Core Courses		
Course		Units
Introduction to Electrical Engineering	ECE 109/109L	3/1
C for Engineers	ECE 114/114L	3/1
Introduction to Combinational Logic	ECE 204/204L	3/1
Introduction to Sequential Logic	ECE 205/205L	3/1
Network Analysis I	ECE 207/207L	3/1
Network Analysis II	ECE 209/209L	3/1
Electronic Devices & Circuits	ECE 220/220L	4/1
Object-Oriented Programming	ECE 256	4
or Programming for Engineering Application	ECE 257	(4)
Electromagnetic Fields	ECE 302	4
Introduction Discrete Time Signals & Systems	ECE 306	4
Computer Simulation of Dynamic Systems Lab	ECE 306L	1
Network Analysis III	ECE 307	3
Control Systems Engineering	ECE 309/309L	4/1
Introduction to Power Engineering	ECE 310/310L	4/1
Prob, Stats, & Random Processes for ECE	ECE 315	4
Linear Active Circular Design	ECE 320/320L	3/1
Introduction to Semiconductor Devices	ECE 330	3
Introduction to Microcontrollers	ECE 341/341L	3/1
Communications Systems	ECE 405/405L	4/1
Professional Topics for Engineers	ECE 464	1
Team Project	ECE 467	1
Total Units		77

Elective Core Courses	
Course	Units
ECE Upper Division Electives	21
12 of the 21 units must be 400 level courses. A minimum of one lab (either 300 or 400 level) is required. If a course has an associated lab, both must be taken.	
Total Units	21

Required Support Courses		
Course		Units
General Chemistry	CHM 121	3
General Chemistry Lab (B3)	CHM 121L	1
Analytic Geometry/Calculus I (B4)	MAT 114	4
Analytic Geometry/Calculus II	MAT 115	4
Analytic Geometry/Calculus III	MAT 116	4
Calculus Several Variables I	MAT 214	3
Calculus Several Variables II	MAT 215	3
Linear Algebra & Differential Equations	MAT 224	4
Materials Science & Engineering	MTE 208	3
General Physics (B1, B3)	PHY 131/131L	3/1
General Physics	PHY 132/132L	3/1
General Physics	PHY 133/133L	3/1
Project Design and Applications (B5)	EGR 481, 482	4
Total Units		45

General Education Requirements		IGE (G.E. Alternative)
Area	Units	
Area A Communication & Critical Thinking	12	IGE 120 4
1 Oral Communication		IGE 121 4
2 Written Communication		IGE 122 4
3 Critical Thinking		IGE 220 4
Area B Mathematics & Natural Sciences	16	IGE 221 4
<i>Select at least one lab course from sub-area 1 or 2.</i>		
1 Physical Science		IGE 222 4
2 Biological Science		IGE 223 4
3 Laboratory Activity		Area A1 4
4 Math/Quantitative Reasoning		Area A3 4
5 Science & Technology Synthesis		Area B 16
Area C Humanities	16	Area C1, C2 or C3 4
1 Visual and Performing Arts		Area C4 4
2 Philosophy and Civilization		Area D4 4
3 Literature and Foreign Language		
4 Humanities Synthesis		
Area D Social Sciences	20	See University Catalog for information on how IGE meets G.E. requirements.
1 U.S. History, Constitution, American Ideals		
2 History, Economics and Political Science		
3 Sociology, Anthropology, Ethnic & Gender Studies		
4 Social Science Synthesis		
Area E Lifelong Understanding & Self Development	4	
Total Units	68	

American Institutions Courses that satisfy this requirement may also satisfy G.E. Area D1	8
---	---

American Cultural Perspectives Requirement Refer to catalog for list of courses that satisfy this requirement. Course may also satisfy major, minor, GE, or unrestricted elective requirements.	4
---	---

The following required support courses should be taken to satisfy the indicated GE Requirements to achieve the minimum units to degree listed at the top of this sheet.

Course	GE Area
General Physics	PHY 131/131L B1, B3
and General Chemistry Lab	CHM 121L B3
Analytic Geometry/Calculus I	MAT 114 B4
Project Design and Applications	EGR 481, 482 B5

The remaining GE requirements may be satisfied by any course approved for that area.

No more than 105 community college quarter units or 36 extension credit quarter units may be applied toward a Bachelor's degree.
A minimum 2.0 cumulative GPA is required in core (including option) courses, Cal Poly Pomona courses, and overall work completed in order to receive a degree in this major.

Electrical Engineering Curriculum Flow Chart

Year 2012/2013

Name: _____

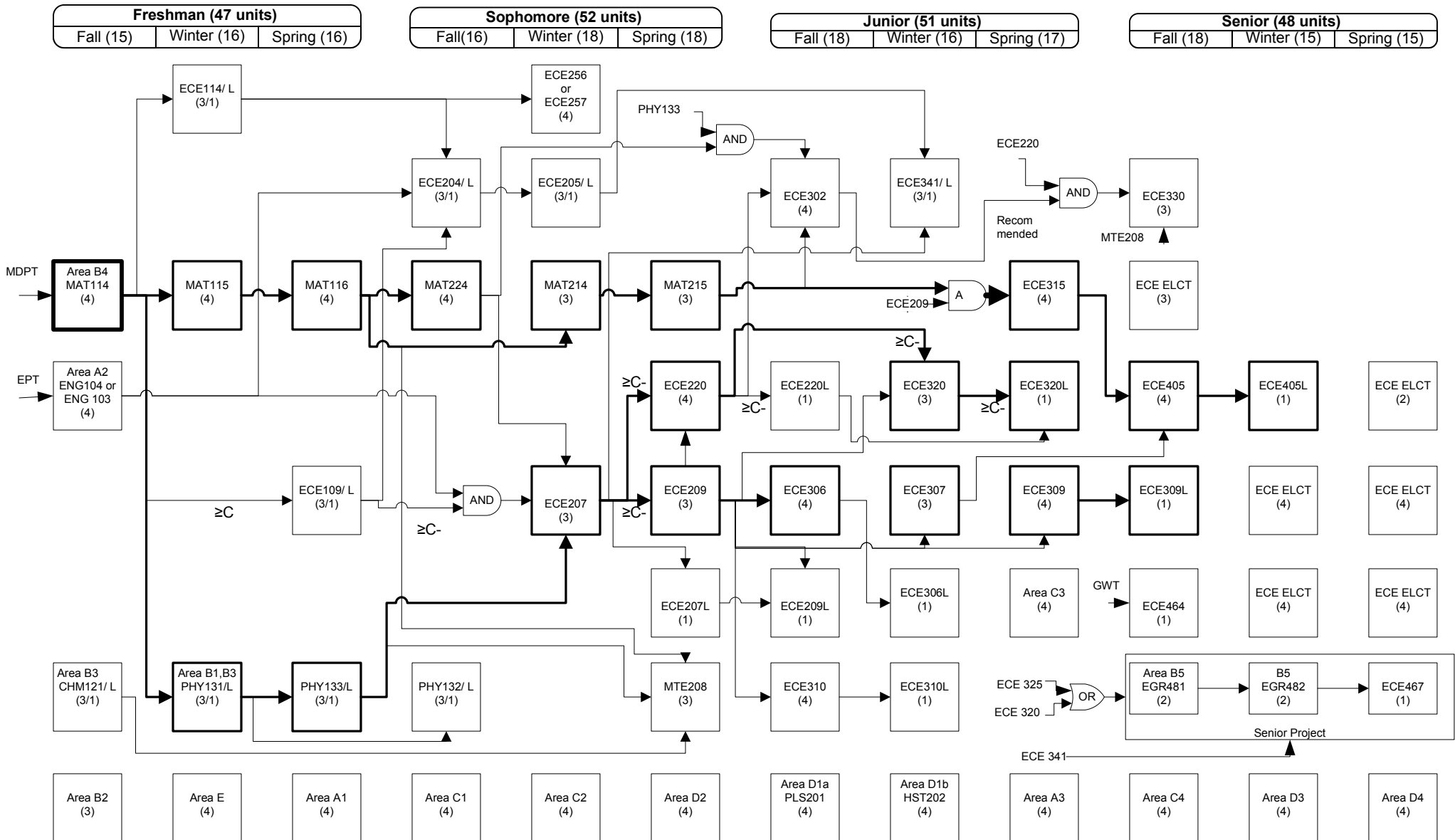

- BS Electrical Engineering degree requirements include 21 units of upper division electives, and:**
- 1- A minimum of one lab (either 300 or 400 level) is required.
 - 2- If a course has an associated lab (The lab is listed as corequisite to the Lecture), both must be taken.
 - 3- 12 of the 21 units must be 400 level courses